

## Australian Standard Compliance & Acoustic Data

### DSA Class 37 STC- Rw Acoustic Systems Component

- **DS-44** head and jamb seal
- **DRS1530** automatic door bottom seal

- **Standard silver anodised aluminium finish**
- **Seal material, TPE thermoplastic, (black)**

All the above seals systems have been tested in accordance with:

#BCA F & BCA 2.2.2, #BCA. J2.4, #AS. 4420. 4.&.5, #BCA. 2.6.1, #AS. 2047. AS. 12. 88, #AS. 1939, #IEC (529 ), #AS. 1530.7 and FSE 004, #BCA. F. 5, #BCA. P. 2. 4.6, #AS. 1191, #(ISO 140. 3), #AS. 1276, #AS. 2253 #ADM 0298. 01 #BCA. D. 3, 8. C. 2. 5, #BCA – C.3.4. C. 3.6. D.2 6, #BCA P2.3.4, #BCA. A.2.3 A2.4.C. 3.5, #AS 1503. 4, #AS./NZ. 1905. I, #AS.1530.7, #AS 1735. 11, #BCA. G. 4. 5, #BCA. D.P.2, #BCA. D.3, #AS1428, #AS. 1735. 12.

Door Type	Acoustic Door - 45mm	45mm
No Seals	<b>STC</b>	<b>Rw</b>
Fully Caulked	20	21
<b>Acoustic Performance Door System</b>	<b>37</b>	<b>37</b>

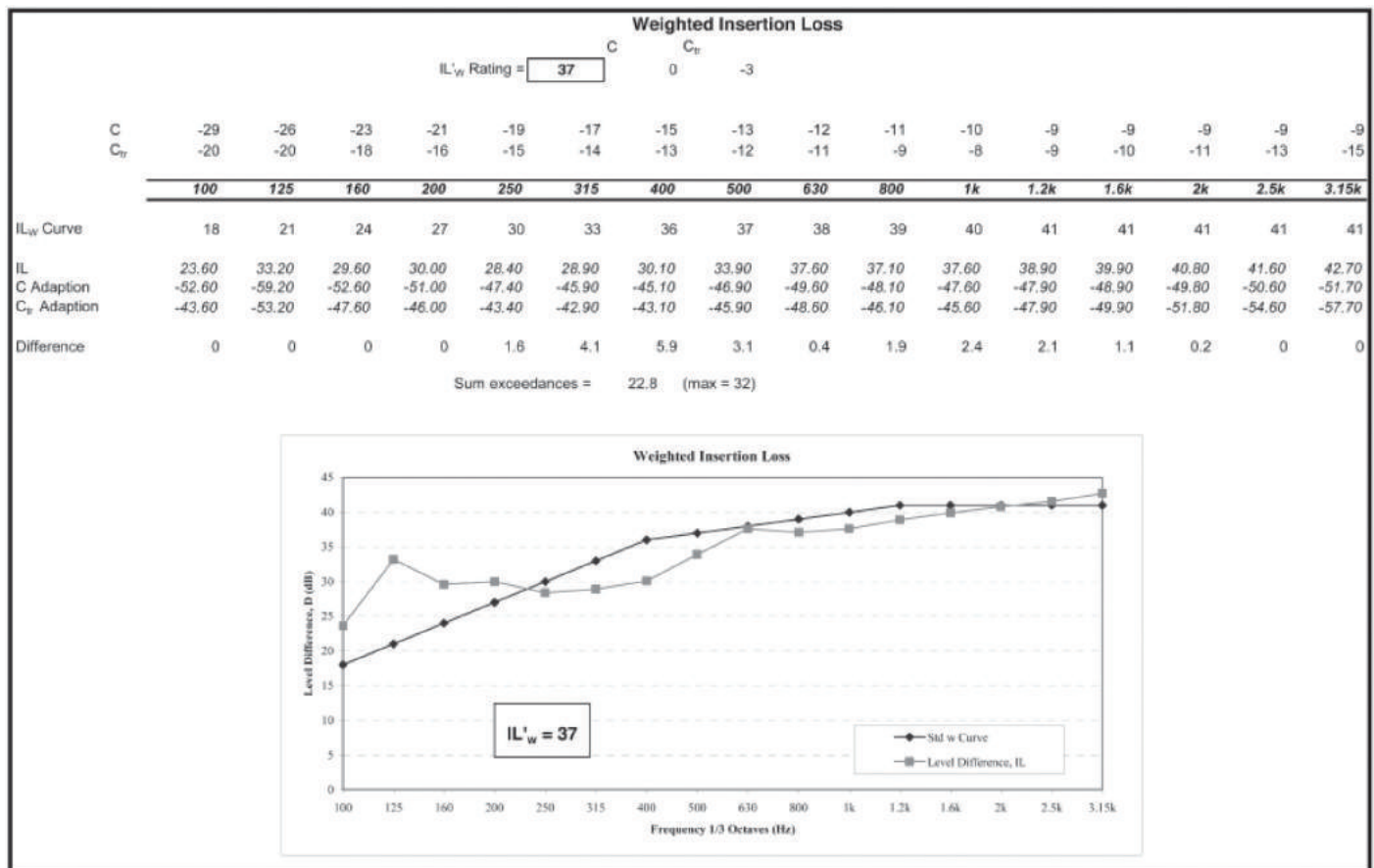

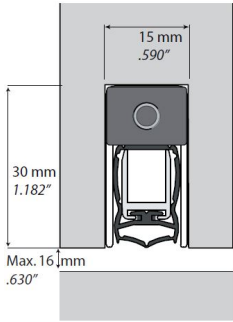

**DRS1530**

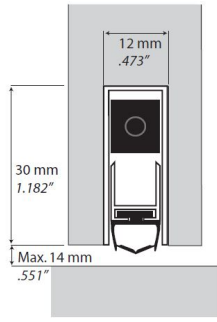

**DBS1230**

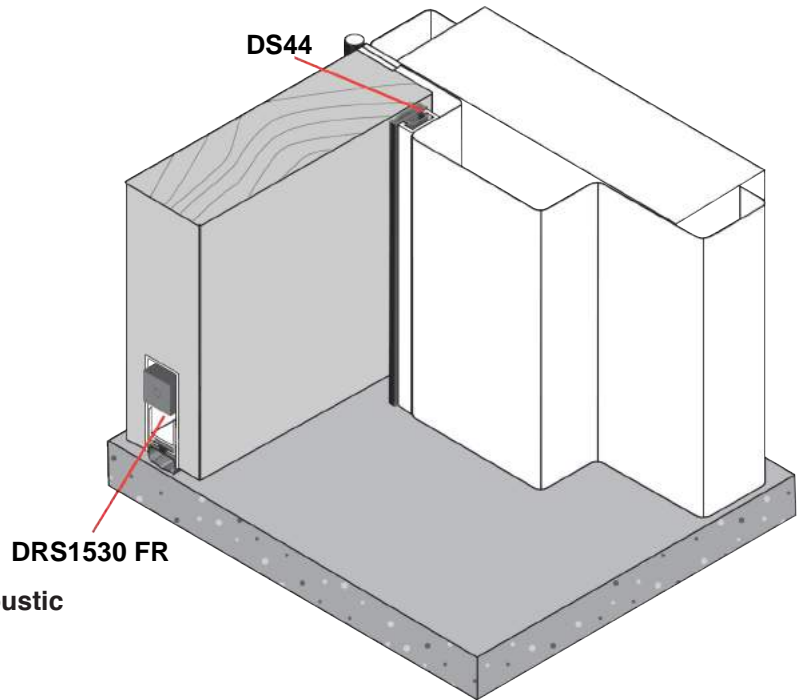

**DSA Class 37 STC-Rw Acoustic Systems Component.**

The **DS44** is a high performance and economical door seal which can be installed on door stops of sufficient depth. The corner can be mitred or butt joined. 10 mm clearance is recommended. The DRS1530 and DBS1230 are fully mechanical automatic door bottoms that utilise a flat spring mechanism, which activates when the door is closed. Lowering a TPE seal insert against the floor or threshold, protruding, hinge-side plunger is compressed by the frame as the door closes to activate the spring. The seal then drops in a scissors like motion from the hinge side. Use a 3mm hex spanner to adjusting to the floor from a pivoting point. This motion ensures a smooth drop without drag for a tight seal, even on an uneven floor. As the TPE seal compresses the seal performs.

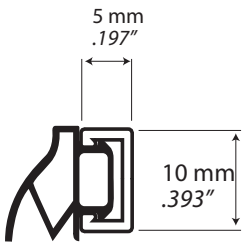

**DS44**

Approvals: Fire: AS1530.4 Smoke: AS1530.7/BCA C3.4 Acoustic: AS1191/ISO140.3/ISO10140.2